



Schunk Carbon Technology

Heat Treatment

Customized solutions for
your heat treatment needs

Schunk Carbon Technology: Always at your side

Schunk Carbon Technology focuses on development, manufacture and application of carbon and ceramic solutions. It combines innovative spirit and technological expertise with exceptional customer service to provide a range of products and services unique to the market. In Schunk Carbon Technology, you have a partner who can offer all the technological possibilities of an international company and implement ideas custom-tailored to your needs, both for high-volume industrial markets and for highly specialized niche markets.

A Schunk Group division

Enabling, idea-driven, cooperative – if you hope to apply technology to develop better products and capture new markets, we can help. The Schunk Group has been supporting customers with innovative technologies since 1913. As an idea-driven technology company, innovation is fundamental to our culture. We forge long-lasting, cooperative working relationships with our clients.

You will find our custom-tailored high-tech products and systems in markets such as carbon technology and ceramics,

environment simulation and air conditioning technology, sintered metal and ultrasonic welding.

The Schunk Group is active in a large number of key industries, from automotive, rail, aviation and marine technologies to solar and wind energy, medical and electrical technology as well as the semiconductor industry. Our more than 8,000 employees in 29 countries are ready to serve you.

High Temperature Applications: Material expertise for the most extreme conditions

Our premium carbon solutions are used in nearly every thermal application: heat treatment, medical and analysis technology, the glass industry and solar technology. Schunk Carbon Technology offers a broad spectrum of graphite, carbon fibre-reinforced carbon and ceramics, carbon and graphite felt materials and components for these applications. Together with solutions devised by our technical ceramics business unit, we have a spectrum of products and services for high temperature applications and heat engineering available nowhere else in the world.

Thermal processes firmly under control

In the area of heat treatment and tempering, we have assembled a product portfolio that sets standards in technological development. This includes everything from furnace components, insulation materials and charge carrier systems to burning aids and solutions for temperature measurement.

We combine innovative solutions, such as new patented processes for relining Hot Zones, silicon material solutions and intelligent charge carrier designs, with our distinctive material and application expertise to create solutions that bring economy, energy efficiency and a long service life.

Made-to-order industrial solutions

It's good to know what markets need. It's even better to provide the technological answers. As a global leading specialist for high temperature applications, Schunk Carbon Technology has solutions and ideas to benefit every market, including:

- hollow glassware industry
- components and systems for the photovoltaic industry
- delicate, yet high-performance, graphite components for analysis and medical technology



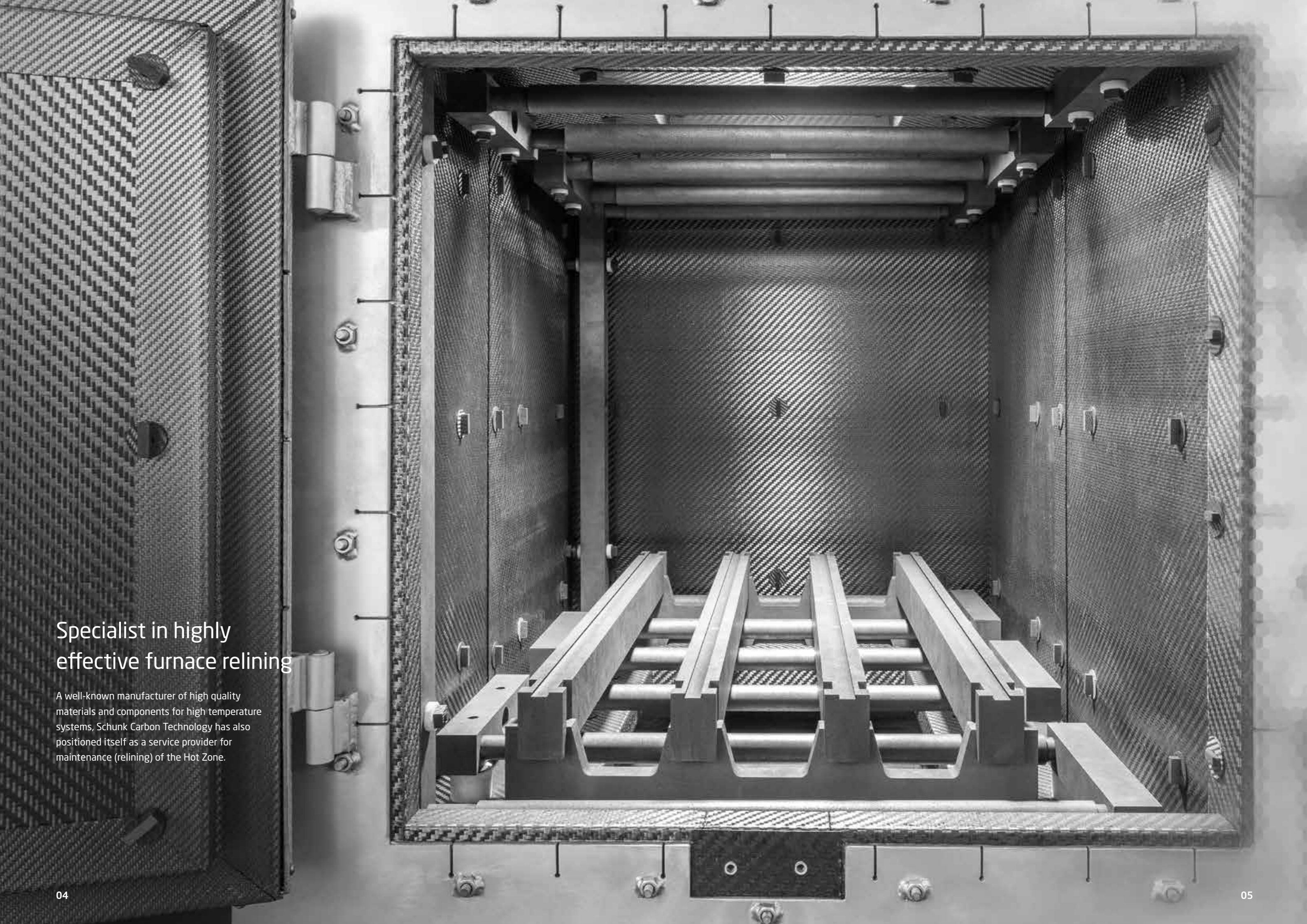

Specialist in highly effective furnace relining

A well-known manufacturer of high quality materials and components for high temperature systems, Schunk Carbon Technology has also positioned itself as a service provider for maintenance (relining) of the Hot Zone.

Service life of the heating chambers

Gas quenching vacuum furnaces are subject to many aggressive chemical and mechanical effects that damage the furnace insulation.

If the furnace malfunctions due to insulation damage, repairs are often complex - resulting in lengthy, expensive downtime. With high quality insulation materials, Schunk offers the best possible protection:

- MechTherm® (very good mechanical properties)
- InsuTherm® (outstanding insulation properties)
- OxaTherm® (special resistance to chemicals)

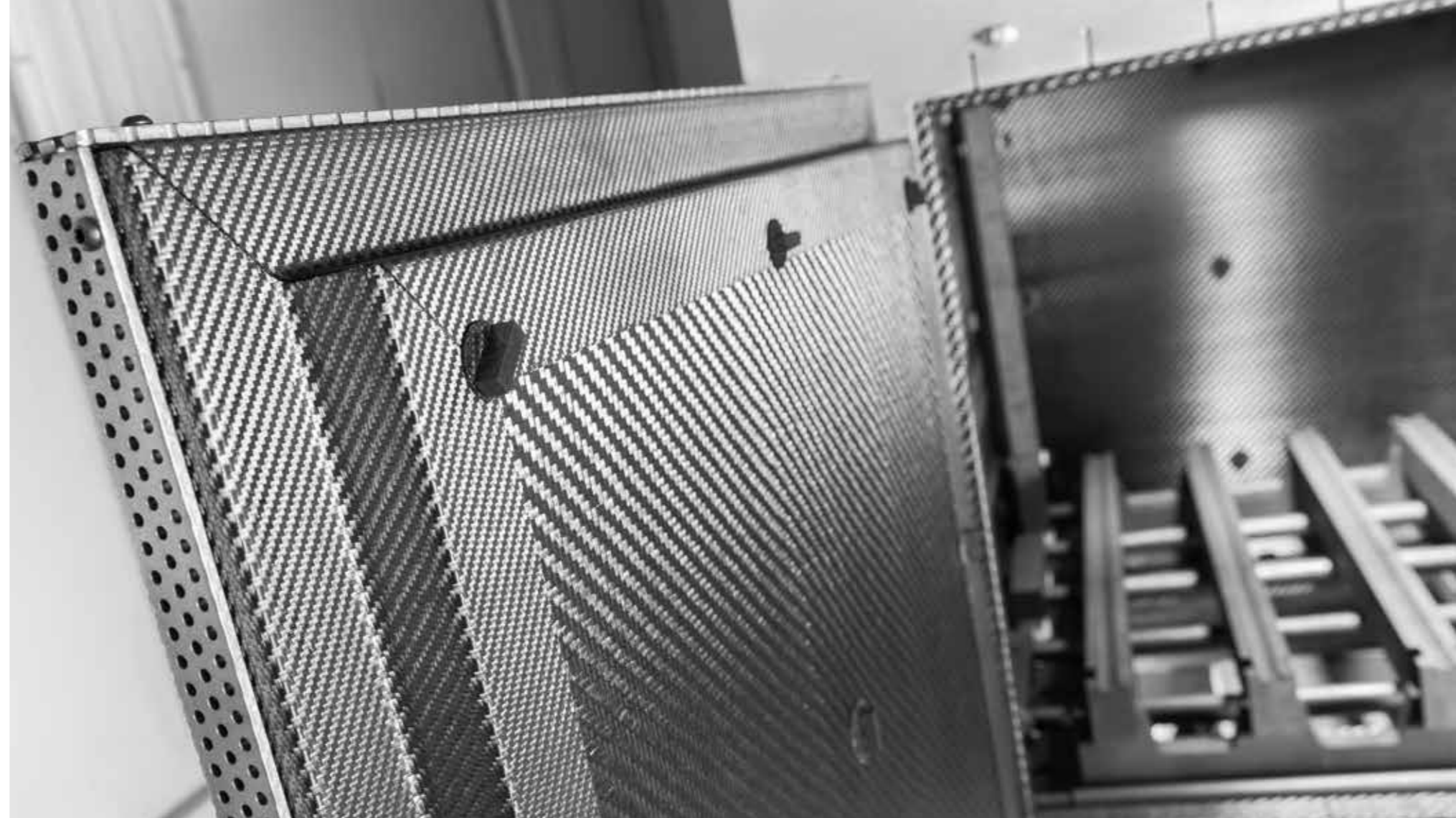

▲ Patented double-L-profile for door-protection



▲ Expert reline service

Comprehensive service

We offer the complete renovation of the Hot Zone, or relining, as a full service that provides you with a considerable increase in value - with the high quality typical for Schunk.

In doing so, we focus entirely on your individual needs:

- After an on-site review and meticulous consultation, our service specialists remove your Hot Zone. We disassemble the worn materials properly and refurbish them at our location, precisely customized to your specific requirements. Then we reinstall the renovated Hot Zone in your furnace system and, together with you, we check to make sure that the system is running again within the specified parameters.
- If you carry out the maintenance yourself, after we clarify your needs we put together an optimum mix of materials, including felt, C/C, graphite, ceramics, molybdenum, etc. for you - all from a single source.

Greater efficiency and longer service life

With our service, we not only want to maintain your vacuum furnace; we want to do more: In close cooperation with you, we develop individualized solutions and improve the functionality of your furnace. Our relining significantly improves temperature uniformity as well as the efficiency and service life of your system.



C/C mounting elements

Optimization with innovative materials and components

With our patented components made of C/C, we are setting new benchmarks for the relining of vacuum furnaces:

- Our double-L profile is an innovative solution for longer service life of the door insulation. Because abrasive and mechanical wear primarily affects the insulation in the door area, we have developed a two-level profile that provides perfect protection for door edges. We cover the door insulation in a manner similar to a picture frame. In this way, the insulation remains permanently in place - the sealing surfaces are completely protected.
- Another innovation: our replaceable thermocouple insert. When thermocouples are installed in the Hot Zone, the insulation in the door area is damaged. This results in

thermal bridges, which have a negative effect on an even temperature distribution. Only the new thermocouple insert by Schunk solves this problem. Without destroying the insulation, you can install the prefabricated insert quickly and easily and replace it based on wear.

- Conventional mounting elements made of molybdenum become brittle under the effects of high temperatures. The result: they break, batches can be damaged, the stability of the insulation decreases. Replacing molybdenum mounting elements is a complex, expensive process. By using our robust C/C mounting elements, you avoid this problem. Because the Hot Zone does not need to be removed, a repair made from the inside of the Hot Zone is much easier and faster. Doing it this way is a safe bet!

Precise documentation

You receive the respective data sheets and factory test certificates for all of the materials and components used. This detailed documentation makes an important contribution to quality assurance, which also gives extra value to your customers.

Highest quality - everywhere on the globe

As our customer, you benefit from both our expertise as an international manufacturer of top class materials for high temperature applications and our outstanding service. You get everything from a single source; in your furnace system is nothing but 100% Schunk. You can rely on our continuously controlled, precisely documented top quality that is consistent across Europe - and with it you achieve optimum process reliability.



▲ *Refurbished Hot Zone*

▼ *Patented thermocouple insert*

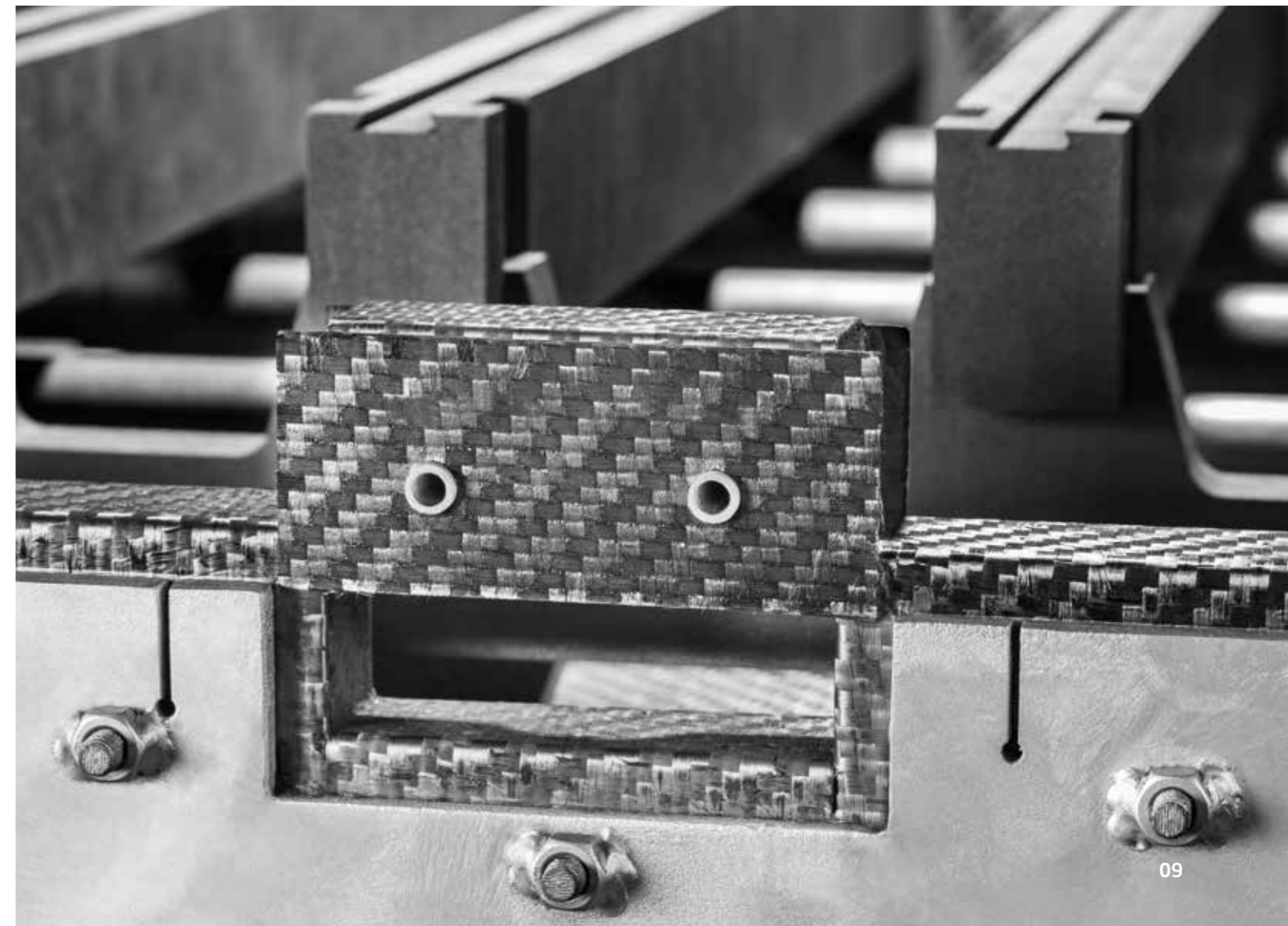

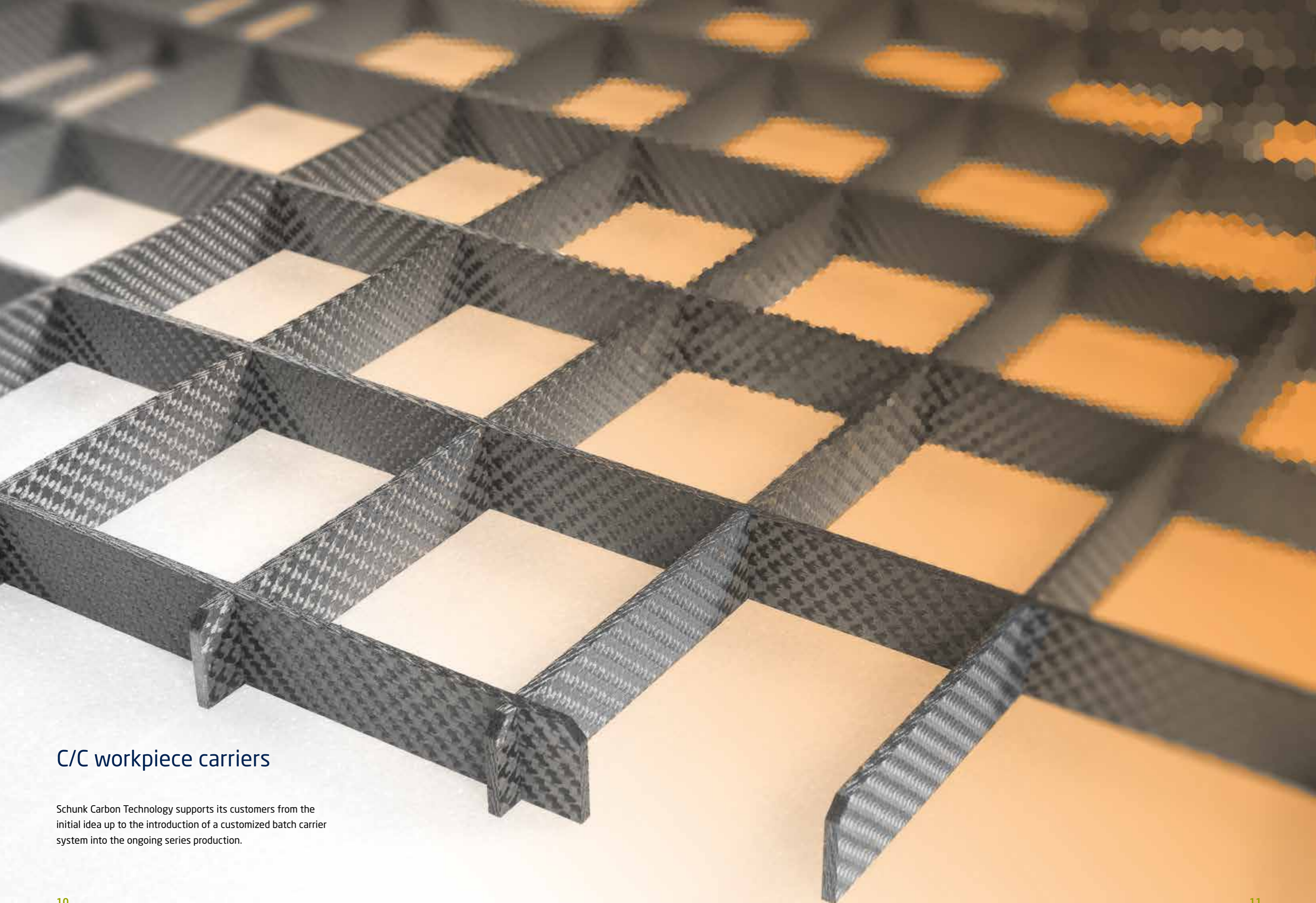

C/C workpiece carriers

Schunk Carbon Technology supports its customers from the initial idea up to the introduction of a customized batch carrier system into the ongoing series production.

C/C workpiece carriers

Disadvantages of traditional cast metal grids

Traditionally, workpiece carriers made of high-alloyed cast materials are used in the heat treatment industry. However, at high temperatures, these systems have serious disadvantages. Due to the lack of creep strength, after just a few furnace runs the workpiece carriers are deformed, which can, in turn, result in the deformation of the treated parts.

Another disadvantage of cast materials is their high density and the associated high thermal capacity. When vacuum heat treating processes are carried out more often, particularly in conjunction with gas quenching, this can lead to

poorer hardness results, greater part deformation, longer process times and increased reworking and process costs. In addition, the deformation of the workpiece carrier prevents automated loading and unloading, which has a negative effect on throughput and economic efficiency.

Advantages of C/C workpiece carriers

Compared to steel, the properties of carbon fiber reinforced carbon materials (C/C) are ideal for workpiece carriers used in the higher temperature ranges because they offer many advantages, such as:

- high strength
- no deformation, even at high quench rates
- no reworking
- very long service life
- low density, so they are considerably lighter than steel
- reduction in thermal mass
- optimum ratio of workpiece carrier weight to part weight
- greater furnace loading and higher capacity
- higher productivity
- reduction in cycle time
- more consistent part hardness quality
- reduction in part distortion
- less reworking
- greater quenching speed
- higher energy efficiency
- lower operational costs
- optional automated loading and unloading



Deformation after 9 month



Slim design with C/C weight saving 20 kg

▼
Interlocked C/C grid for a design load of 10t



Customer-specific solutions

Schunk Carbon Technology supports its customers from the initial idea up to the introduction of a customized batch carrier system into the ongoing series production. Our engineering team will be pleased to develop C/C batch carriers that are customized for your individual requirements.

Schunk Carbon Technology has a comprehensive expertise:

- in our own materials manufacturing
- with an extensive materials portfolio
- with many years of experience in the design of batch carriers
- in our own design process, using FEA analysis
- with a global network of sales organizations with top class after-sales service

UniGrid® - Unique, modular, cost-effective

With UniGrid®, Schunk Carbon Technology offers not only customer-specific batch carriers, but also standardized solutions for C/C grids. In contrast to machined or water-jet cut grids, these grids, manufactured in a single, separate process, have a continuous fiber structure and no joints. The closed frame structure enables easy, uncomplicated handling with a high degree of rigidity and strength.

This modular batch carrier system offers a wide variety of possibilities for positioning graphite supports, this allows you the greatest possible flexibility when loading the grids. Our graphite supports are self-centering, both in our UniGrid® grids and with respect to each other, this makes them easy to mount and align. The graphite supports can be stacked and offer excellent stability for multi-level structures.

▼
UniGrid® MT (1,000 x 600 mm²)

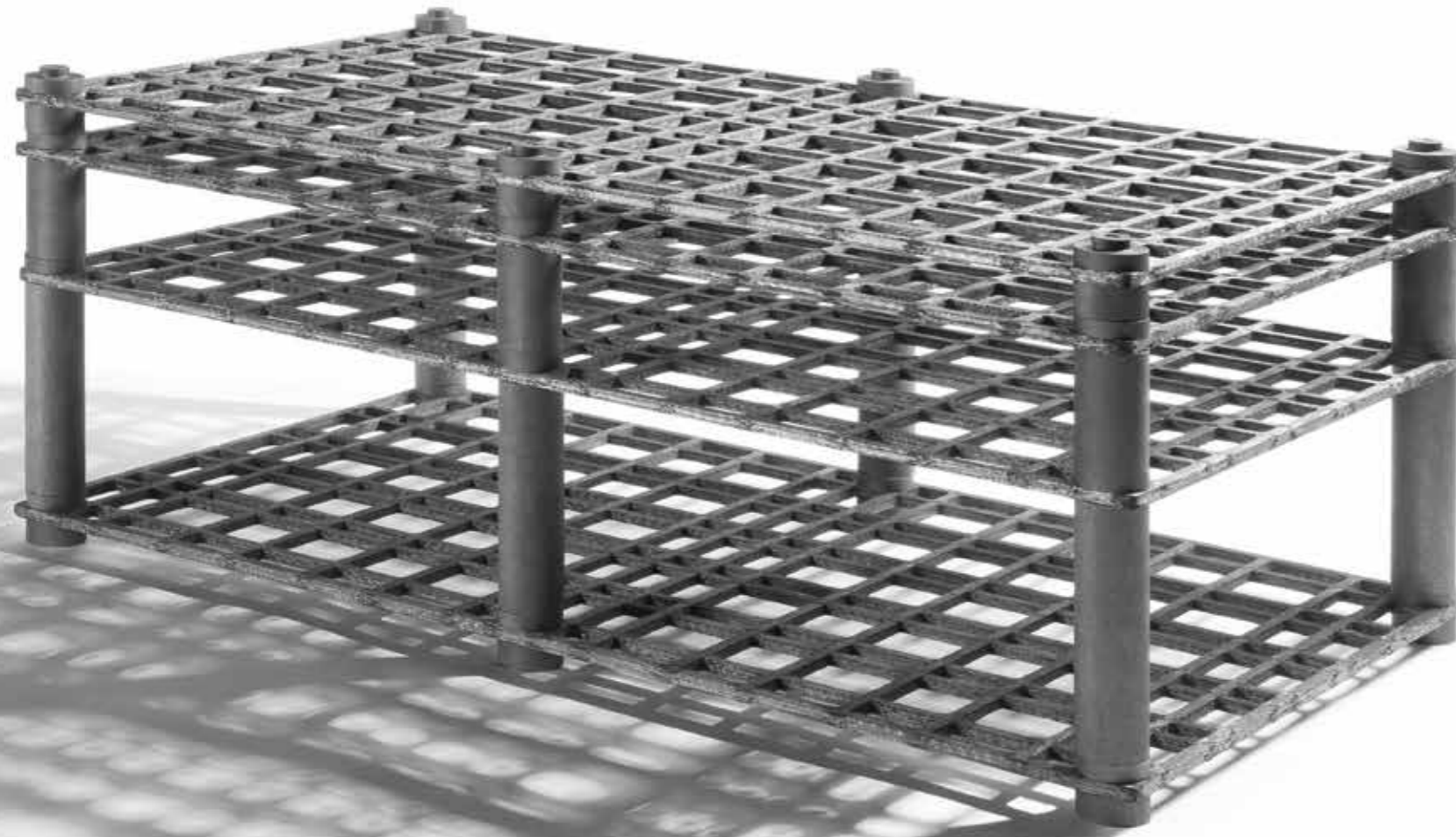

CarboGard® - Protects against contact reactions

At application temperatures above 1,050°C, contact reactions (carbon diffusion) can occur between the hardening stock and the UniGrid®. Our ceramic CarboGard® plates and rings offer a light, thermal shock resistant option for protecting your hardening stock from undesirable carbon uptake.

The CarboGard® standard plates fit exactly into the openings in the UniGrid® system. In this way, the CarboGard® provides the flexibility necessary to meet the requirements and, at the same time, reduce thermal mass.

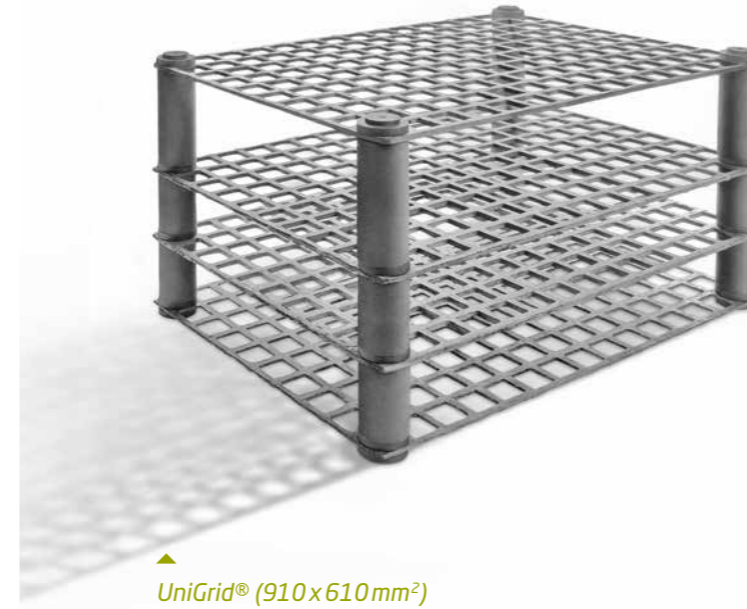

Machined and water-jet cut C/C grids

We work together with you to create optimum solutions based on your requirements and to find out which batch carrier will yield the best results for you. Schunk Carbon Technology produces both machined and water-jet cut C/C grids:

- ▮ machined grids made of C/C allow for a flexible design; the rigidity of the grid can be set precisely using the web height. They are particularly well suited for use with high weight loads with minimum deflection.
- ▮ water-jet cut C/C grids are ideal for low to medium weight loads. The water-jet cutting technology enables precise, low-cost machining in which even fine structures can be implemented.

▼
C/C grid assembly with water-jet cut components

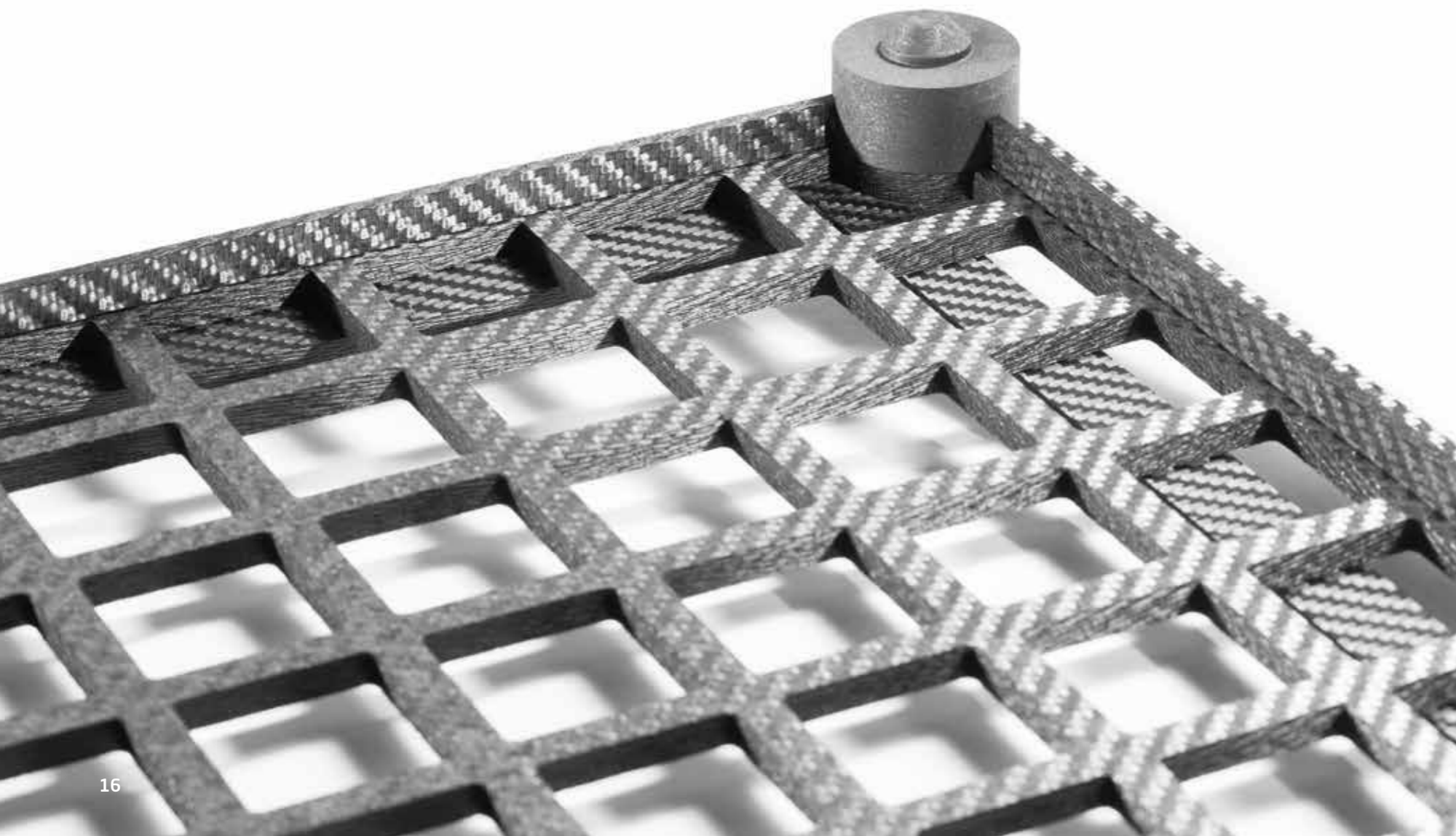

▲
Customized design

Surface modifications for special requirements

All C/C workpiece carriers can be modified at the surface as necessary with various processes. This way, wear resistance can be increased by siliconizing the surface and the service life of the grids can be increased. In addition, Schunk Carbon Technology offers coatings based on pyrocarbon (PyC) and ceramic materials, e.g. oil quenching.



Ceramic coating on C/C

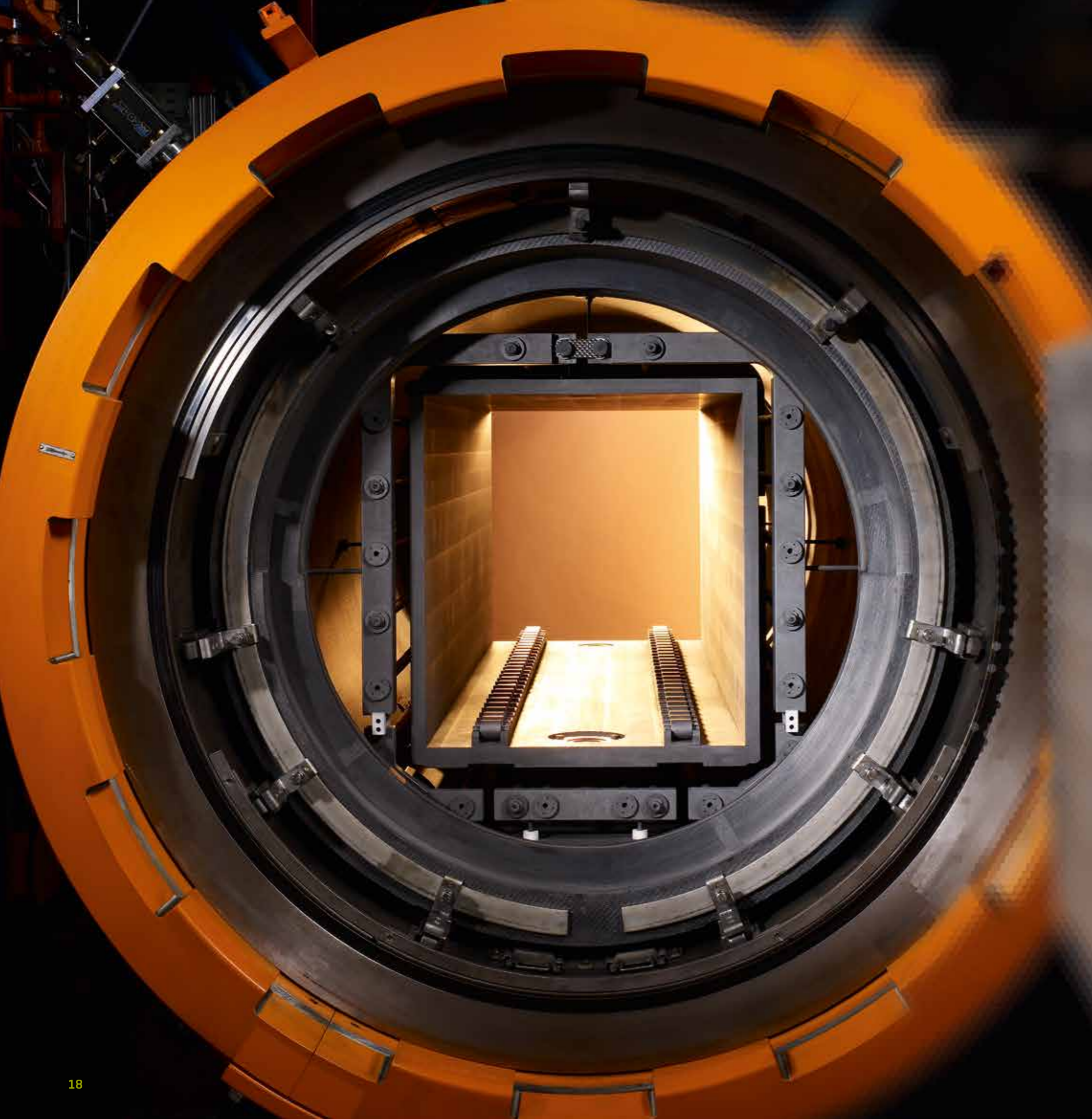

Your innovative partner in the sintering and carbide industry

Schunk Carbon Technology is your innovative development partner for customized components made of graphite and carbon fiber reinforced carbon materials (C/C). With our expertise, you increase your productivity, process reliability and quality in the sintering and carbide industry.



C/C support rings for axial hot pressing

C/C support rings by Schunk set benchmarks with a long service life and outstanding dimensional stability. To guarantee high quality when pressing and sintering ceramic powder at high temperatures and under high pressure, we offer wrapped C/C sintered support rings

- with high wall thicknesses,
- with large dimensions,
- in high quantities and
- customized for your needs.



Sintered plates for any requirement

For rods, drills or indexable inserts - we have the perfectly suited sintered plate for each of your products.

Depending on the requirements, we supply you with various sintered plates made out of **graphite**: the entire spectrum from extruded to isostatic pressed graphite. No matter if it's a contoured or flat surface: we cover a wide range of geometries. We comply exactly with your specifications and ensure consistent processing quality.

C/C, a very light and stable material, offers significant advantages in comparison with graphite when used for sintered plates. We are happy to advise you regarding the switch from graphite to C/C sinter plates. We use FEM (finite element method) calculation to find the optimum plate thickness for your requirements in order to increase your productivity.

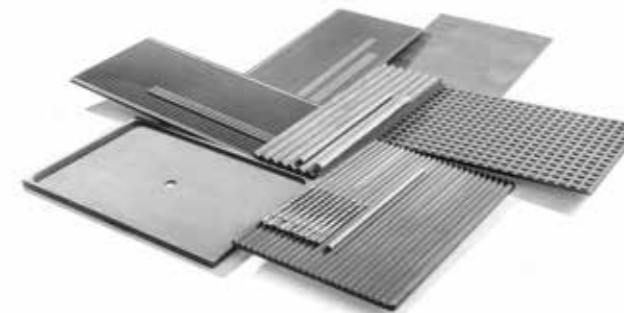

Graphite sinter plate

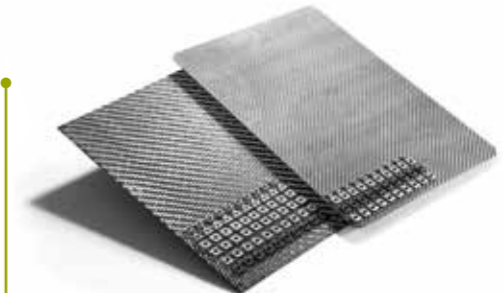

C/C sinter plate

Spare parts - We provide help fast

To ensure the trouble-free operation of your sintering furnace continuously, we have a wide variety of spare parts available:

- insulation material
- C/C plates and profiles
- C/C and graphite films
- screws, nuts and other auxiliary materials

Graphite and C/C components for CVD coating

For the CVD process, Schunk supplies all of the components made of graphite and C/C materials. These have been proven in application and are best suited to meet the challenges of CVD coating.

For any desired dimensions and for simple or highly complex designs, we ensure consistent, high quality with our components made of graphite.

Due to its positive material properties, the use of C/C for **charging plates** offers particular advantages:

- ▣ increased productivity per production batch
- ▣ no brittle breakage behavior, so no batch loss
- ▣ improved ability to plan
- ▣ longer service life
- ▣ reuse by removing CVD coating layers



C/C plates for CVD-process

By substituting graphite with C/C charging plates, productivity can be increased by 10% in the example. ▶

+ 3 layers = + 10% productivity

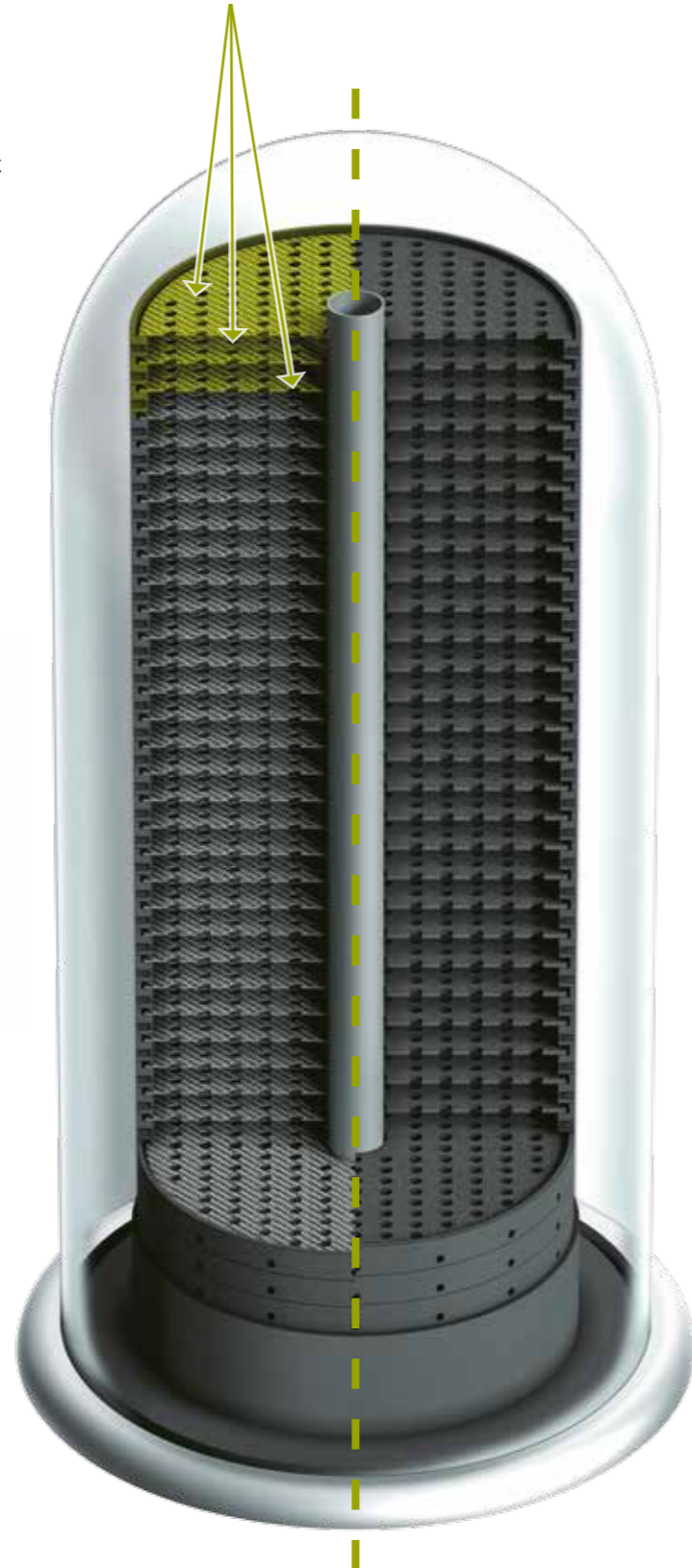

Coating removal - An innovative solution

When you coat your products, you also inadvertently coat your charging components. As soon as the layers begin to peel off (particle release), the service life of these components is at an end. So that the production batches are not damaged, up to now the charging components have been scrapped.

With the professional **removal** of the coating on the charging components, we have developed a method for reprocessing and reusing the components, which saves resources and is cost-effective. The removal of the coating layer is primarily suited **for use with C/C components** because of its positive effect on costs.

Due to possible hairline cracks and brittle breakage behavior, charging plates made of graphite are only used for one application period. For this reason, cost-effective coating removal is not usually possible, with the exception of a few components - e.g. solid graphite support rings. In contrast, coating removal allows C/C charging plates to be used for multiple and, moreover, longer application periods.

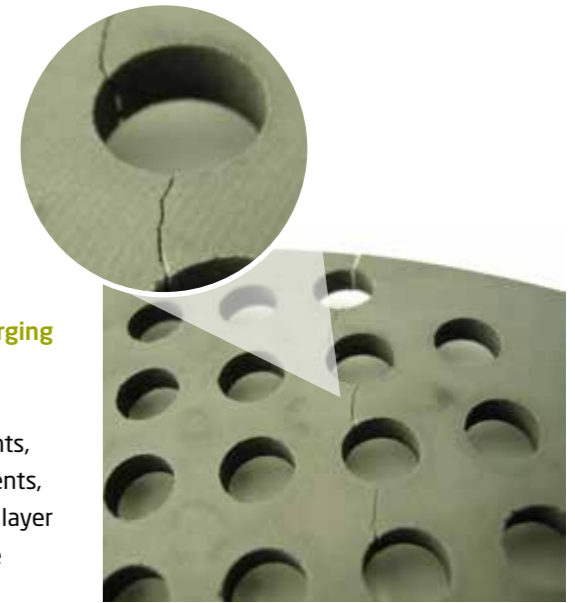

▲ Graphite plate with hairline cracks - any further use is not possible

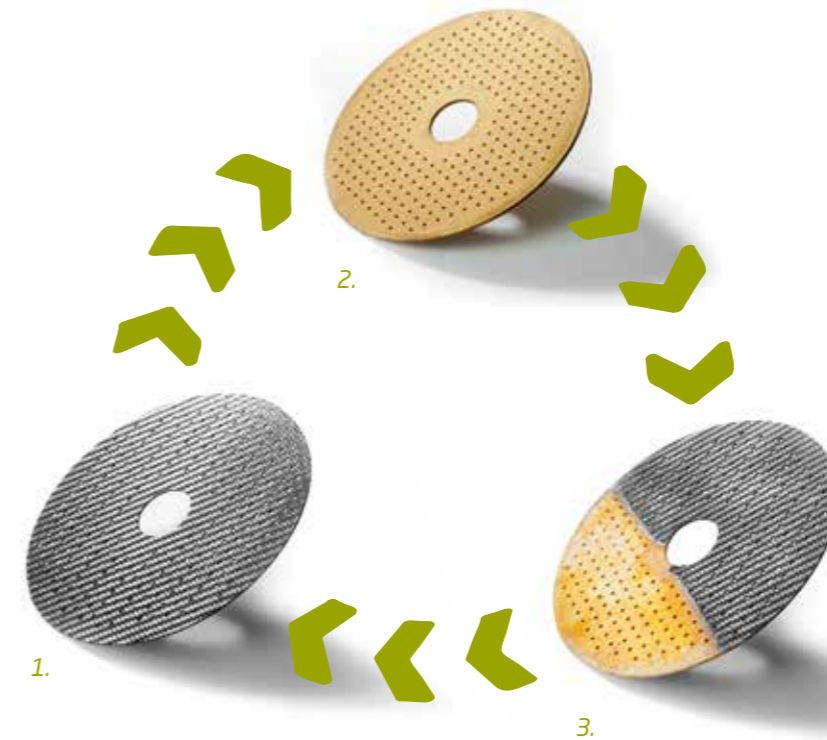

- ◀
1. New respectively cleaned C/C plate
 2. C/C plate after many coating cycles
 3. C/C plate during cleaning process

Schunk Kohlenstofftechnik

Rodheimer Strasse 59

35452 Heuchelheim ▯ Germany

Phone +49 641 608-0

Fax +49 641 608-1673

Email division-carbontechnology@schunk-group.com

www.schunk-carbontechnology.com



20.03e/1.000/2016

