

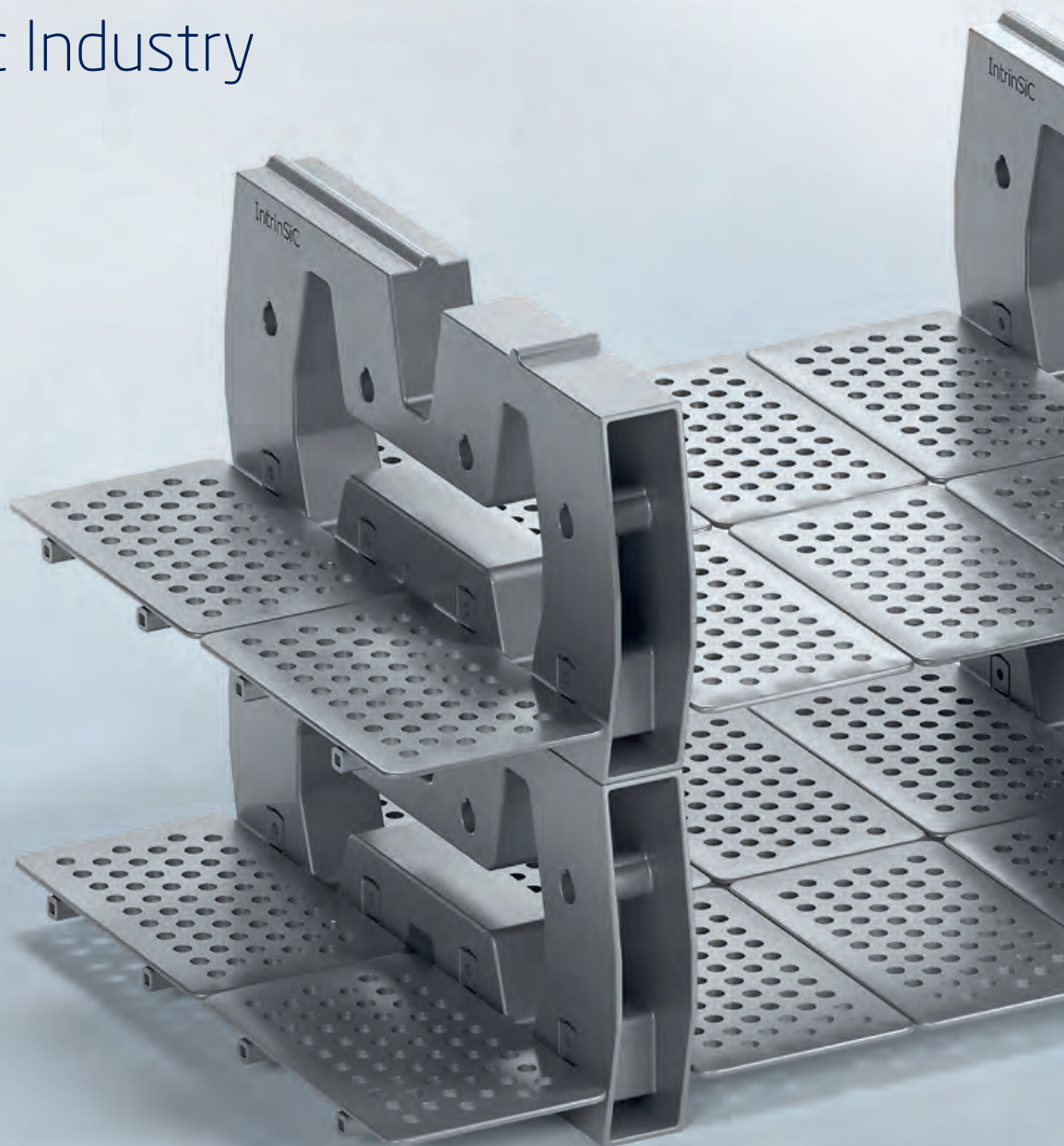

Schunk Carbon Technology
Ceramic Industry





Advanced Solutions Accelerating Your Way to Innovation.

To enable cutting-edge developments with our customers we established "Advanced Solutions" – a business unit that covers all the technological know-how of the Schunk company and offers solutions with an added value. Keeping this in mind, Advanced Solutions enables you to discover the revolutionary and develop the customized products. Advanced Solutions can be considered as Schunk's business incubator for new approaches, materials and technologies encompassing carbon, ceramics and quartz. We grow products from ideas thus paving the way for industrial trends and providing the technological solutions for your applications. Advanced Solutions opens new markets and enables growth opportunities. Through technological cooperation with our partners, we ensure the success of our customers.

Process Added Value Engineering (PAVE) is our unique method to develop new products that precisely meet our customers' requirements. You will profit from our innovative spirit, customer-oriented practices and an efficient realization of serial production.

Advanced Solutions has access to our entire company like to a toolbox. Our four core areas of expertise include a comprehensive material know-how in carbon, ceramics and quartz; precise customizing of the intrinsic material properties to specific applications, state-of-the-art forming technologies for efficient production lines and tailor-made high quality surface treatment of the final products.

By combining and advancing our production techniques, we meet your specific requirements. We call it PAVE – Process Added Value Engineering.

Thanks to our PAVE philosophy, we always start with the solid foundation based on years of expertise but keep our minds open for new ideas. Our customers benefit from the analytical skills of our experts and the practical approach for industrial solutions. Schunk's global production capacities and hands-on mentality of a mid-sized company guarantee rapid and successful development cycles and market introduction.

Schunk Carbon Technology: Always at your side.

Schunk Carbon Technology focuses on the development, manufacture and application of carbon and ceramic solutions. We combine innovative spirit and technological expertise with exceptional customer service to provide a range of products and services unique to the market. With Schunk Carbon Technology you have a partner who can offer all the technological possibilities of an international company and implement ideas custom-tailored to your needs, both for high-volume industrial markets and for highly specialized niche markets.

A Schunk Group division

Enabling, idea-driven, cooperative – if you hope to apply technology to develop better products and capture new markets, we can help. The Schunk Group has been supporting customers with innovative technologies since 1913. As an idea-driven technology company, innovation is fundamental to our culture. We forge long-lasting, cooperative working relationships with our customers.

You will find our custom-tailored high-tech products and systems in markets such as carbon technology and ceramics, environment simulation and air-conditioning technology, sintered metals and ultrasonic welding.

The Schunk Group is active in a large number of key industries, from automotive, rail, aviation and marine technologies to solar and wind energy, medical and electrical technology as well as the semiconductor industry. Our more than 8,100 employees in 29 countries are ready to serve you.



High-End Ceramics for Unique Applications

Temperature and media resistant, non-wearing, extremely hard and bulletproof – no other material combines as many valuable features for industrial use as technical ceramics from Schunk Carbon Technology.

Our high-precision, state-of-the-art manufacturing processes provide high-end ceramic solutions for a broad range of applications. Nobody serves you better than we do. Innovative production processes, such as flexible 3-D printing with IntriSiC, make new and economical applications possible and allow the manufacture of large components, shape diversity, small batches and prototyping.

As a specialist for ceramic materials and components made of silicon carbide (SiC) and aluminum oxide (Al₂O₃), we provide materials and components for thermal processing technology, furnace and system construction and process engineering. Thanks to its outstanding features, our SiC is also used in ballistic protection.

Premium solutions for high temperature applications

Technical ceramics from Schunk Carbon Technology set standards for the use of burner systems for direct and indirect heating, kiln furnitures and furnace and system construction. Thanks to their exceptional oxidation and corrosion resistance, resilience through changes in temperature, and dimensional stability, our premium solutions guarantee economical, energy-efficient and reliable production processes.

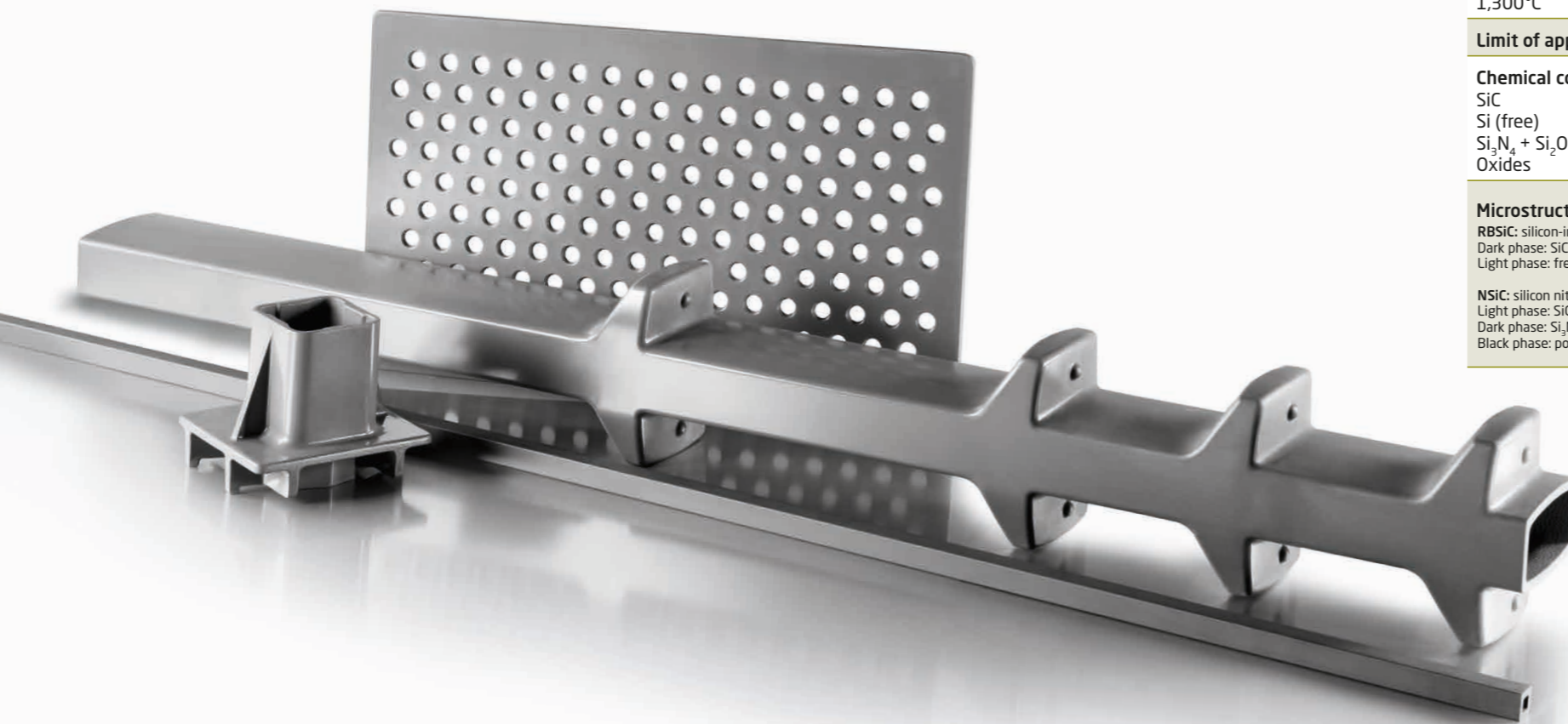

Ceramic Industry

Schunk Carbon Technology develops and manufactures innovative kiln furniture conceptions to improve the efficiency of industrial production processes.

Due to an increasing degree of automation, there is a need for size-optimized components for industrial furnaces to ensure a high degree of efficiency and reliability and thus an optimal utilization of existing furnace capacity.

Especially in this industrial segment Schunk has many years of experience with an extensive product portfolio which includes RBSiC (Silicon-Infiltrated, Reaction-Bonded Silicon Carbide) and NSiC (Silicon Nitride-Bonded Silicon Carbide) and belongs to the technology-leading manufacturers in the world.

		CarSiK	CarSiK-NG	IntriSiC®	Eco-Light®
Nomenclature		RBSiC	NSiC	RBSiC	RBSiC
Bulk density	[g/cm ³]	3.09	2.85	3.07	3.11
Apparent porosity	[Vol. %]	0	<1	0	0
Modulus of rupture	[MPa]	280	200	210	280
Modulus of elasticity	[GPa]	360	220	360	360
Thermal expansion coefficient	[1/°C]				
20° - 1,000°C		4.9 x 10 ⁻⁶	4.6 x 10 ⁻⁶	4.9 x 10 ⁻⁶	4.9 x 10 ⁻⁶
Thermal conductivity	[W/mK]				
100°C		160		160	160
1,200°C		24	12	24	24
Specific heat	[J/kgK]				
RT		600	750	600	600
1,300°C		1,200	1,100	1,200	1,200
Limit of application	[°C]	1,380	1,470	1,380	1,380
Chemical composition	[wt. %]				
SiC		88	65	87	90
Si (free)		11	–	13	9
Si ₃ N ₄ + Si ₂ ON ₂		–	27	–	–
Oxides		–	balance	–	–

Microstructure

RBSiC: silicon-infiltrated, reaction-bonded SiC
Dark phase: SiC
Light phase: free Si

NSiC: silicon nitride-bonded SiC
Light phase: SiC
Dark phase: Si₃N₄/Si₂ON₂
Black phase: pores

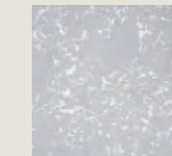
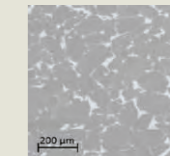
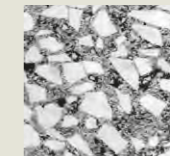

* The values quoted above were determined on test specimens and cannot generally be applied to all shapes.

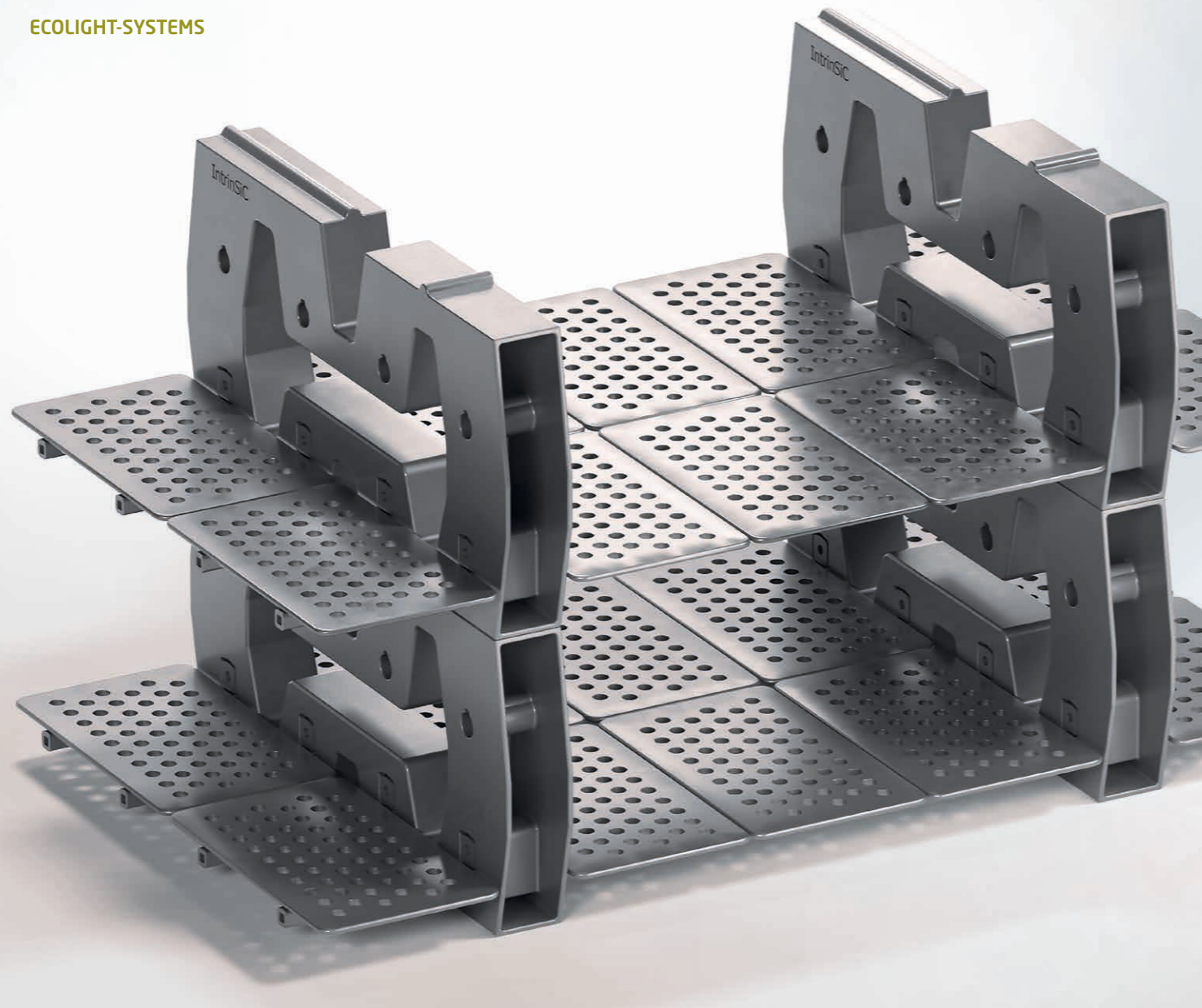

EcoLight-Systems

With innovative EcoLight-Systems, Schunk Carbon Technology sets new industrial standards as far as efficiency is concerned. The individual combination of the superior grades silicon-infiltrated, reaction-bonded SiC (RBSiC), in particular due to our advanced manufacturing process such as 3D-printing, extrusion, pressure-/slip casting, isostatically pressing and silicon nitride-bonded SiC (NSiC), ensures with tailor-made and design-engineered solutions a high degree of reliability and economy in service.

EcoLight-System (for Sanitary)

The below shown kiln car superstructure visualizes an exemplary set-up for a tunnel kiln car. Different set-up configurations (i.e. incl. Lavi Setters, beams for supporting Double-Basins etc.) are also feasible.

Single items (i.e. Eco-Light® Beams, Bore-Grids, Vertical Posts) are also available for Shuttle kilns.



Y-Riser

The single piece 3D-printed riser design in RBSiC grade IntrinSiC® – including an integrated cover plate,

combined with a Y-shaped bottom structure for defined 3-point loading is a new innovation.

Y-Risers are available with separate cover plate, also available washcoated upon request.



Loading Setters

Loading setters offering a high degree of design flexibility are available in our 3D-printed RBSiC-grade IntrinSiC®.



Bore-Grid

The Bore-Grid structure with a max. size of 800 x 600 mm allows a better convective heat-flow and therefore a positive impact on the yield of the ware being fired.

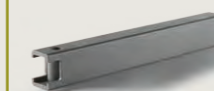

Vertical Posts

A joined/glued insert ensures a defined line-loading of the longitudinal beams and therefore a controlled loading distribution.



Eco-Light® Beams

Eco-Light® Beams from Schunk Carbon Technology are the most innovative product line available for longitudinal beams used in the sanitary industry.

EcoLight-System (for Architectural and Technical Ceramics)

- ↳ Transportable and stackable Set-Up with new innovative interlocking-system in between the stackable Profiles and longitudinal beams (pending patent) allowing high degree of industrial automation
- ↳ Reduced thermal mass and therefore reduction of gas-consumption (mass-optimized designs for the Profiles feasible due to innovative 3D-printed grade IntrinSiC)
- ↳ Improved convective heat-flow due to Grid structures
- ↳ Excellent long term quality-performance

The benefits

- ↳ Reduced thermal mass and therefore reduction of gas-consumption (cost-saving potential approx. > 10% p.a.)
- ↳ Improved convective heat-flow due to Bore-Grid structure with a positive impact on yield
- ↳ Excellent long-term quality-performance
- ↳ Outstanding Product/Service packages

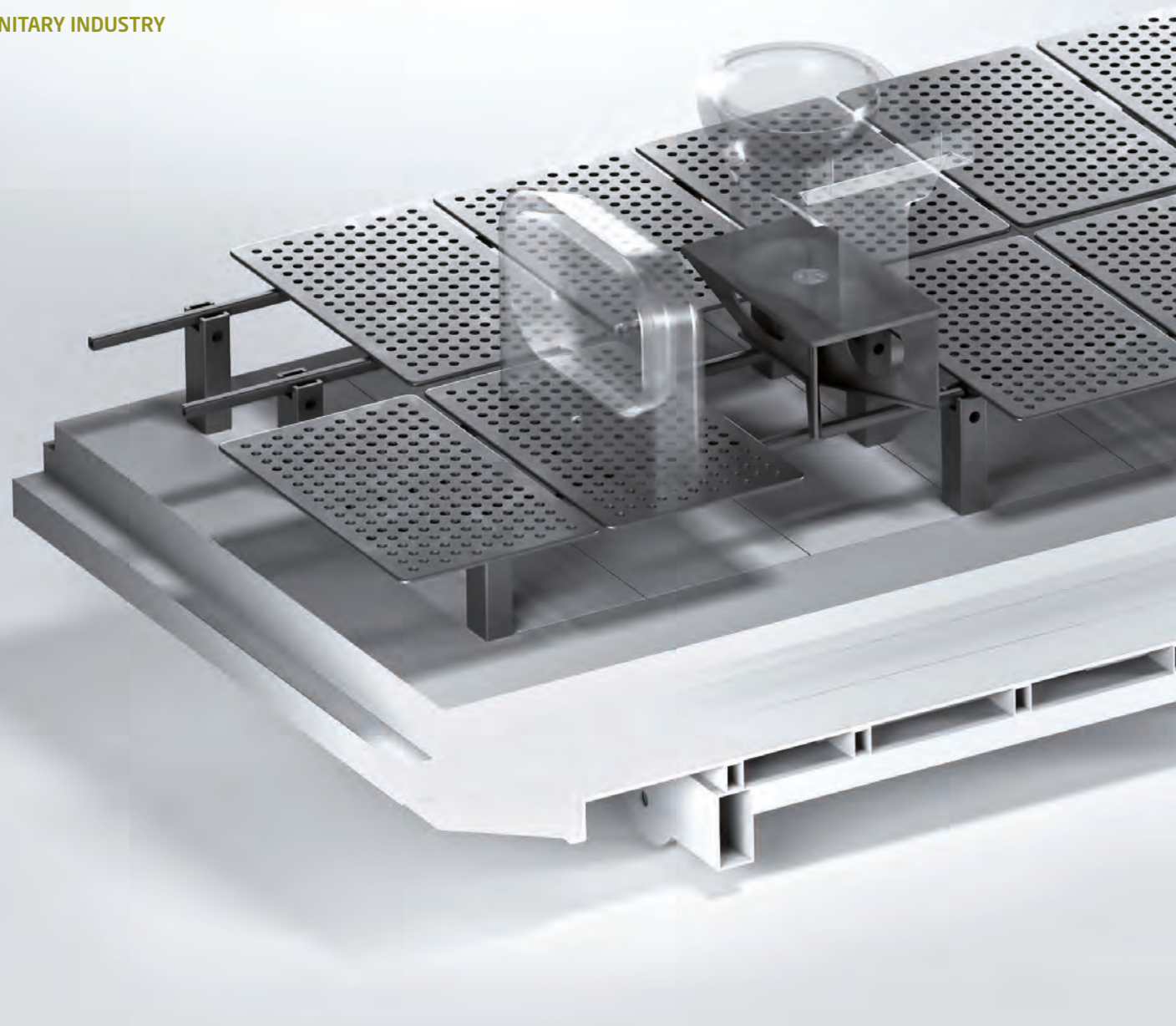

Sanitary Industry

Schunk Carbon Technology is a leading supplier of design elements and kiln furniture systems for single and multi-deck kiln car superstructures for tunnel/shuttle and roller kilns.

Vertical posts with an outstanding long-term quality performance for tunnel- and shuttle kilns are available in mass-reduced standard cross-sections of 80 x 60 mm or 80 x 80 mm. The excellent creep-resistance (no bending compared to cordierite) ensures an optimal function for high-loaded kiln car superstructures.

Customized set-ups e.g. for firing corner basins are available and can be designed by our engineers upon request.

Major benefits of Technical SiC-Ceramics made by Schunk Carbon Technology

- ↗ Excellent long term quality-performance
- ↗ High degree of reliability and economy in service
- ↗ Stability of shape up to material specific max. operation temperature
- ↗ Increased firing capacity and degree of flexibility
- ↗ Excellent oxidation-/corrosion and thermal shock resistance
- ↗ Low-Mass and therefore reduced gas-consumption

Beams and Profiles (RBSiC)

Mass-optimized, customized Eco-Light® Beams allow an elimination of oversized beam cross-sections for longitudinal beams, in particular in the sanitary industry and set an industrial standard as far as efficiency, quality performance and service package are concerned. A combination with CarSiK transverse beams ensures a high degree of reliability and economy in service. Eco-Light® is a high-strength material with excellent hot-bending and creep-resistance.

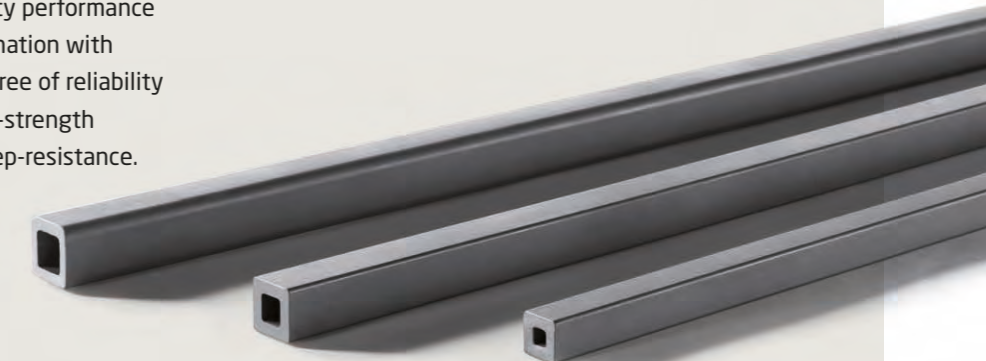

Beams and Profiles (RBSiC)

Bore-Grids and Lavi-Setters (NSiC / RBSiC)

The Bore-Grid structure allows improved convective heat-flow as well as homogeneous temperature distribution and therefore – confirmed by our customers – a positive impact on the yield of the ware being fired. Standard sizes are available up to 800 x 500 mm. Larger sizes can be requested.

Lavi Setters for horizontal firing of vanity basins allow a high degree of planarity to avoid additional grinding of the sanitary wares. Individual designs are available up to a standard area of 800 x 600 mm. Larger sizes and/or washcoating upon request.



Bore-Grid and Lavi Setter (NSiC)

Based on efforts to design unique solutions with the goal of providing highly-efficient products, combined with outstanding service to customers, Schunk Carbon Technology developed as the first supplier in the market the EcoLight-System Sanitary, including an unrivaled service package for the beams consisting of efficiency assessment, product warranty technical consulting and maintenance.

Technical Ceramics

Schunk Carbon Technology supplies a broad spectrum of kiln furniture (e.g. vertical multi-lug posts, beams, profiles, interlocking devices, batts, grids, crucible, shapes) for the firing of technical ceramics (e.g. catalytic converters and diesel-particle filters) with proven excellent long-standing quality performance.



Vertical Posts with multi-tooth structure (NSiC)

Vertical Multi Lug Posts (NSiC)

Vertical posts with tight dimensional tolerances are designed according to meet customers' requirements. Upon request we can also supply gas-tight protection sleeves for the mounting installation within the kiln car plane.

Major benefits of Technical SiC-Ceramics made by Schunk Carbon Technology

- ✔ Excellent long term quality-performance
- ✔ High degree of reliability and economy in service
- ✔ Stability of shape up to material specific max. operation temperature
- ✔ Increased firing capacity and degree of flexibility
- ✔ Excellent oxidation-/corrosion and thermal shock resistance
- ✔ Low-Mass and therefore reduced gas-consumption

Kiln car superstructure for firing of ceramic catalytic converters (exemplary)



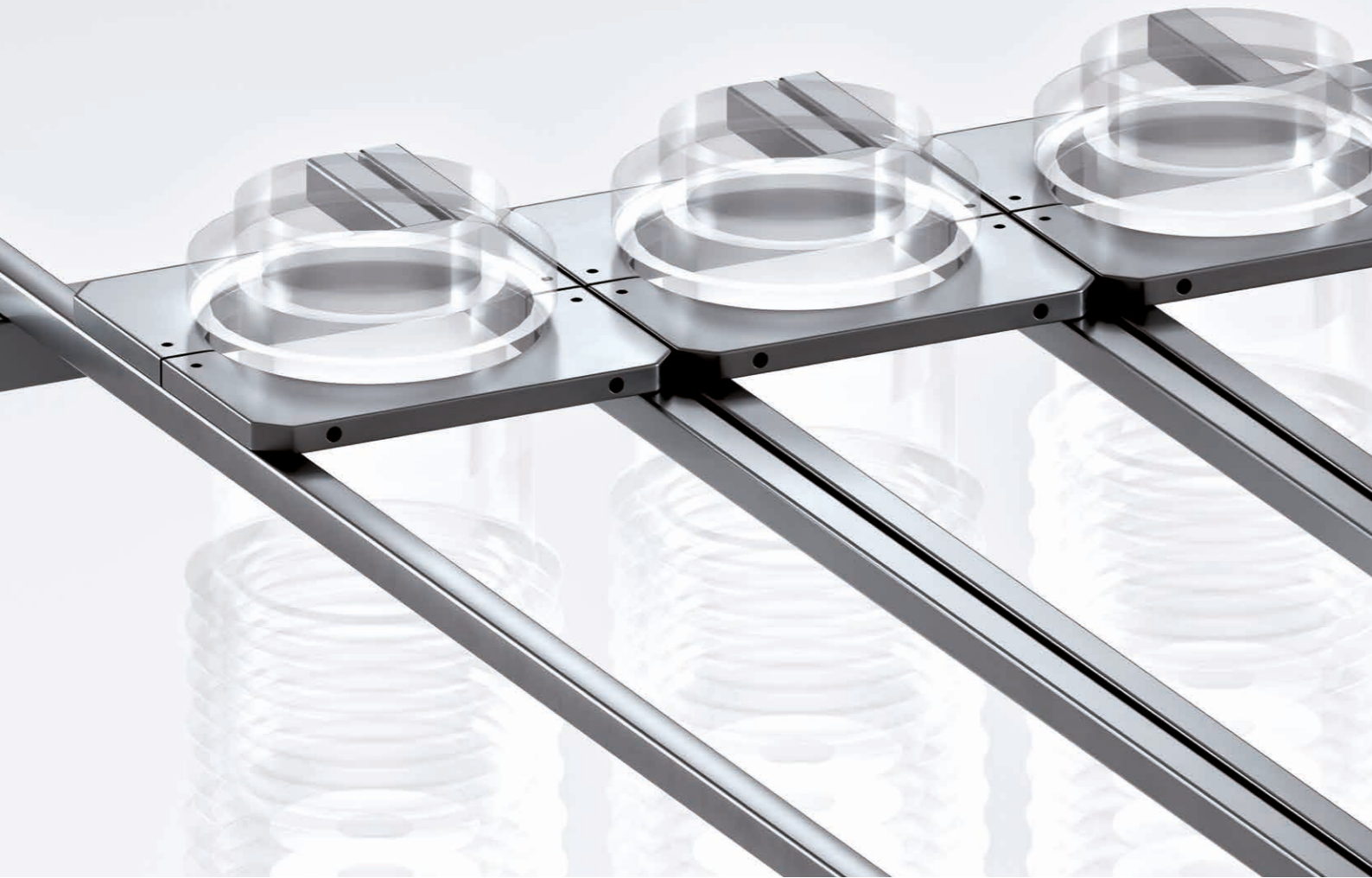

Electroporcelain & Insulators

In particular for heavy-loading kiln-car-superstructures the hang-firing large insulators, Schunk Carbon Technology can provide one of the major product advantages – outstanding bending strengths and creep resistance compared to other commercially available SiSiC beams.

Major benefits of Technical SiC-Ceramics made by Schunk Carbon Technology

- ▮ Excellent long term quality-performance
- ▮ Excellent oxidation-/corrosion and thermal shock resistance
- ▮ High degree of reliability and economy in service
- ▮ Low-Mass and therefore reduced gas-consumption
- ▮ Stability of shape up to material specific max. operation temperature
- ▮ Increased firing capacity and degree of flexibility

Collar Plates (NSiC/RBSiC)

Hollow-cast collar plates ensure a significant improvement in long-term quality performance compared to traditional heavy-load refractory grades.



Collar-Plate (NSiC)

Beams (RBSiC)

In combination with the manufacturing feasibility of extruded large cross-sections up to 100 x 60 mm, we can support our customers in optimizing their set-ups by increasing their firing capacity.

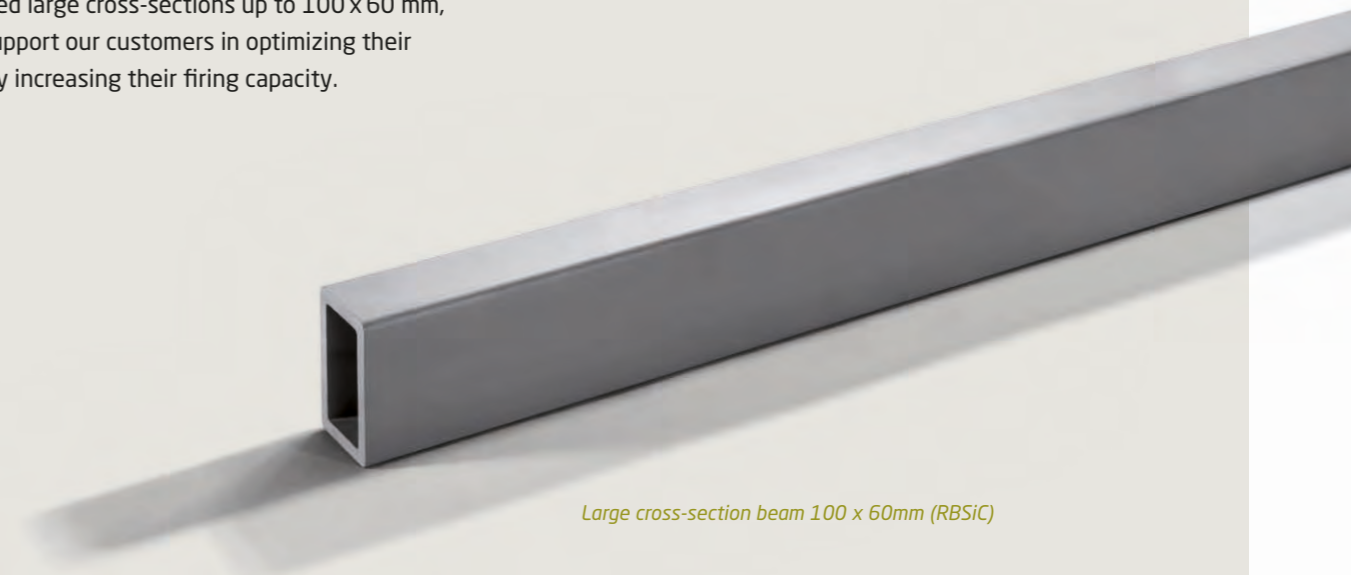

Large cross-section beam 100 x 60mm (RBSiC)

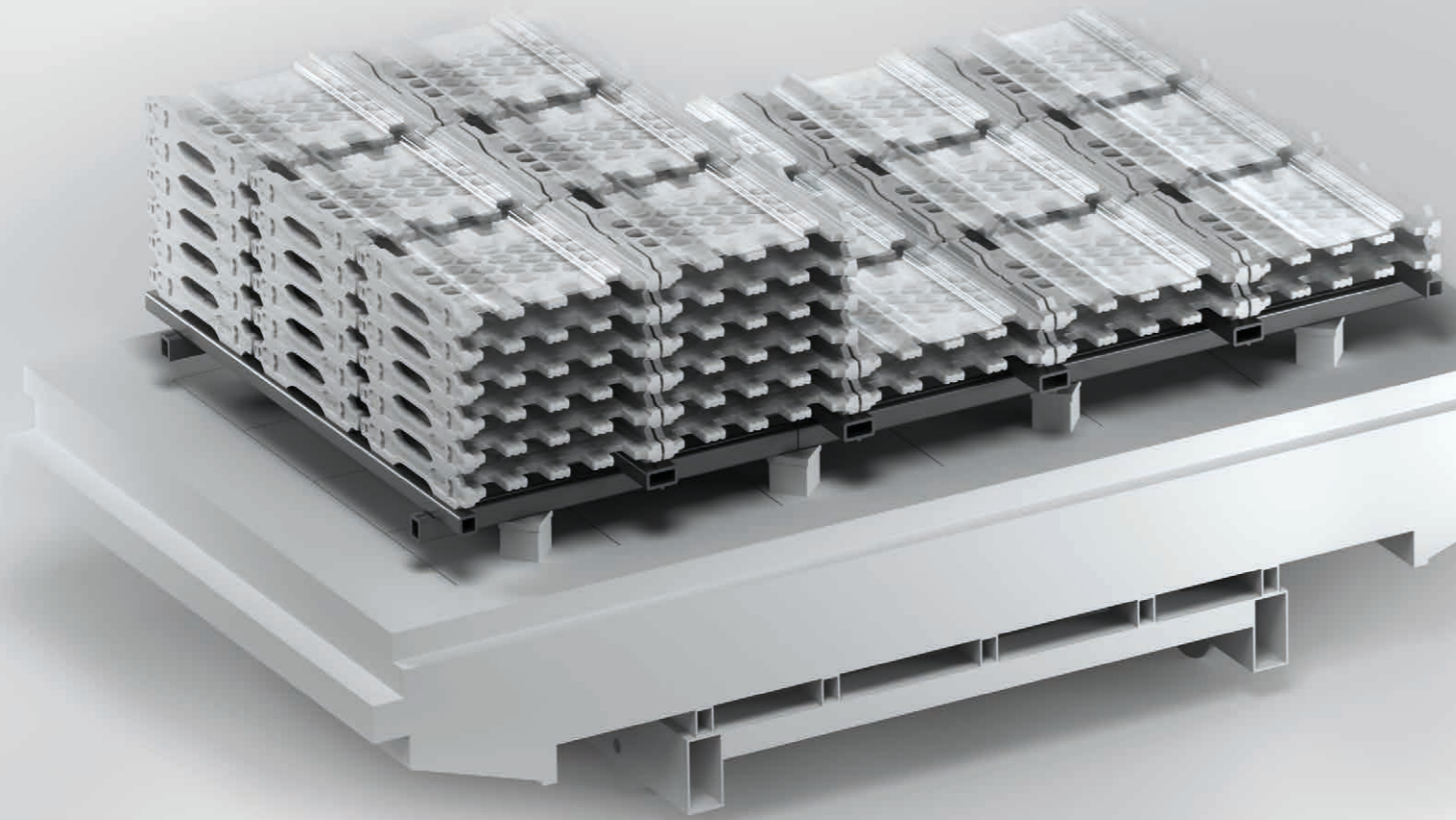

As an alternative to conventional H-cassettes we create design and weight-optimized setters for firing flat tiles and/or accessories within the framework of innovative kiln furniture conceptions. In addition to the molding versions of pressure casting – which ensure the efficient production of large quantities – the innovative manufacturing method of 3D-printing is also available. The Intrinsic® material (3D-printed RBSiC) permits a high degree of freedom and flexibility in design.

With the kiln furniture conception portrayed here, the roof-tile setters are positioned on support tubes with lengths of up to 4200 mm. The load transfer in the assembly visualized here is carried out via stackable supports made of refractory ceramic.

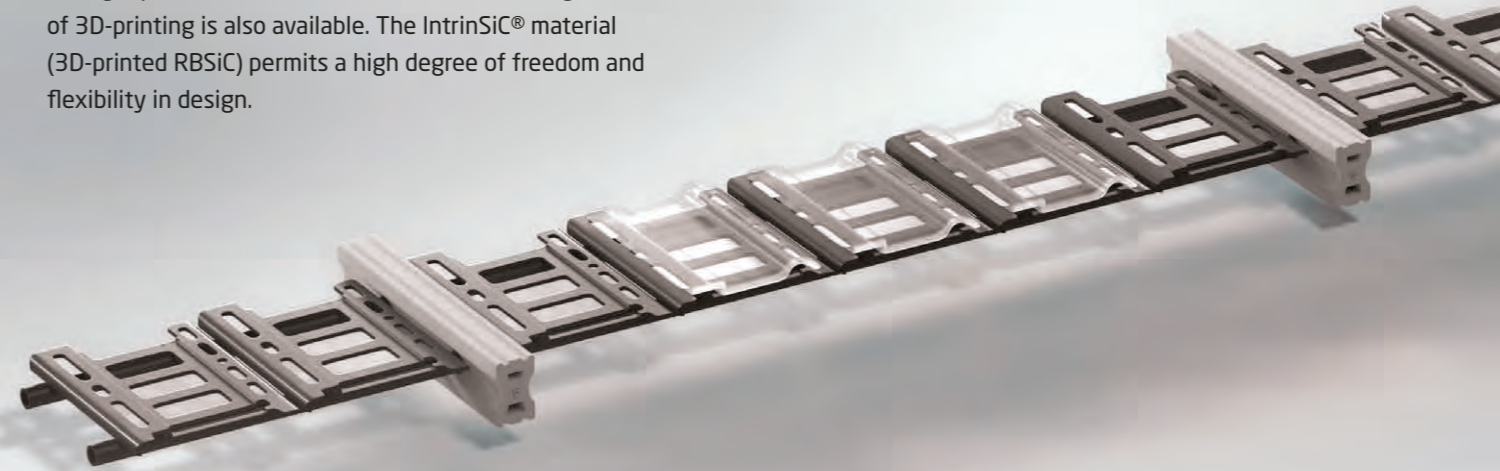

Kiln Furniture System for Roof Tiles

Architectural Ceramics

Within the manufacturing processes of roof-, floor- and wall tiles as well as for bricks, Schunk Carbon Technology offers customized, mass-optimized solutions with the focus on achieving cost-saving. In close cooperation with leading users and kiln-OEMs we develop kiln furniture systems with the goal of supporting our customers in implementing optimized technical solutions.

Major benefits of Technical SiC-Ceramics made by Schunk Carbon Technology

- ↗ Excellent long term quality-performance
- ↗ Stability of shape up to material specific max. operation temperature
- ↗ Excellent oxidation-/corrosion and thermal shock resistance
- ↗ High degree of reliability and economy in service
- ↗ Increased firing capacity and degree of flexibility
- ↗ Low-Mass and therefore reduced gas-consumption

H-Cassettes

For the production of conventional H-cassettes, our innovative 3D-printing method is available, e.g. for prototyping. With Intrinsic® material (3D-printed RBSiC), short delivery times can be realized while eliminating costly modelling and molding work.



H-Cassette and Roof Tile Support (RBSiC)



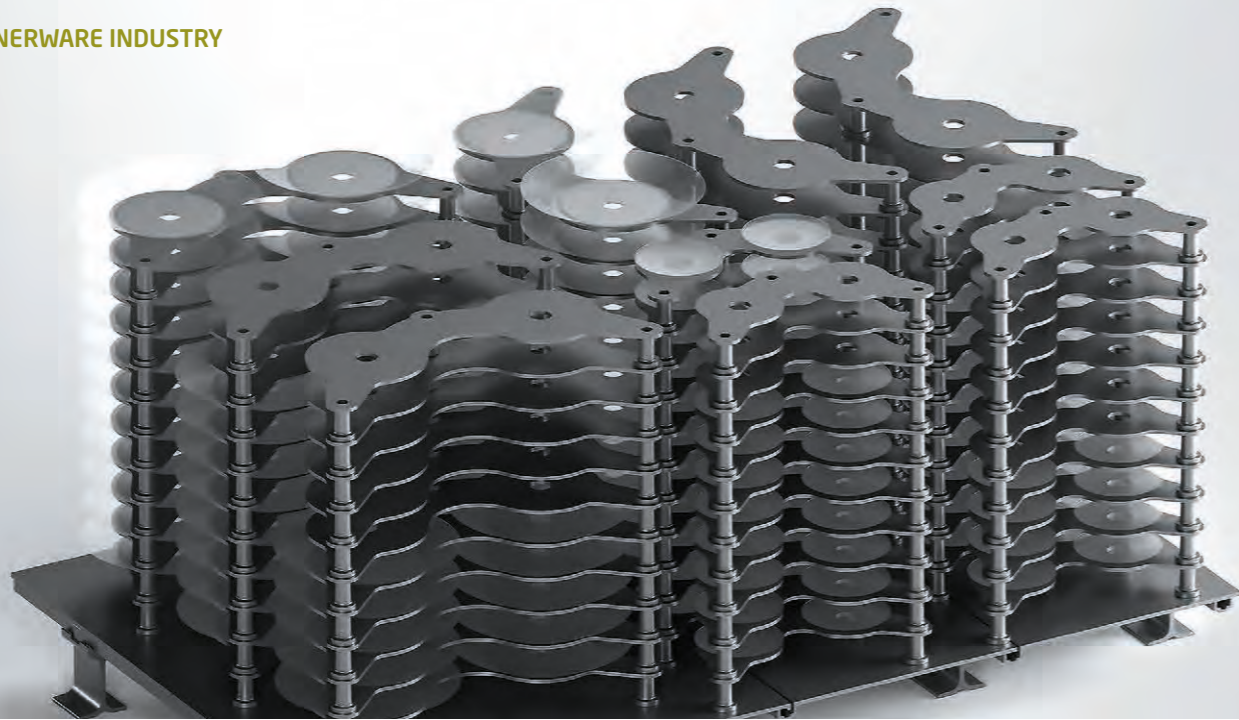

Dinnerware Industry

A high degree of process automation for the loading and re-loading as well as the implementation of the fast-firing-technology for hollow and flatware, used to trigger demand for kiln furniture (e.g. carrier plates, plate-setters, disks, posts, profile beams) with a focus on excellent thermal-shock resistance as well as long-term quality performance combined with a high degree of stability in long term operation as far as dimensional tolerances are concerned. Schunk Carbon Technology offers a broad spectrum of products meeting such requirements.

Plate Setters (NSiC)

Plate setters are available as mono or multi setters in a wide range of shapes and sizes. Washcoating can be provided upon request.



Plate Setters (NSiC)

Major benefits of Technical SiC-Ceramics made by Schunk Carbon Technology

- ✔ Excellent long term quality-performance
- ✔ Excellent oxidation-/corrosion and thermal shock resistance
- ✔ High degree of reliability and economy in service
- ✔ Low-Mass and therefore reduced gas-consumption
- ✔ Stability of shape up to material specific max. operation temperature
- ✔ Increased firing capacity and degree of flexibility



Abrasives

For firing abrasives Schunk Carbon Technology offers complete set-ups consisting of slabs, triangle batts, posts and beams.

Triangle Batts (NSiC)

Due to the low wall-thickness of our triangle batts, as well as for plane slabs, made of technical SiC ceramics, customers are able to increase the setting-density within the kiln car superstructure, increasing efficiency.

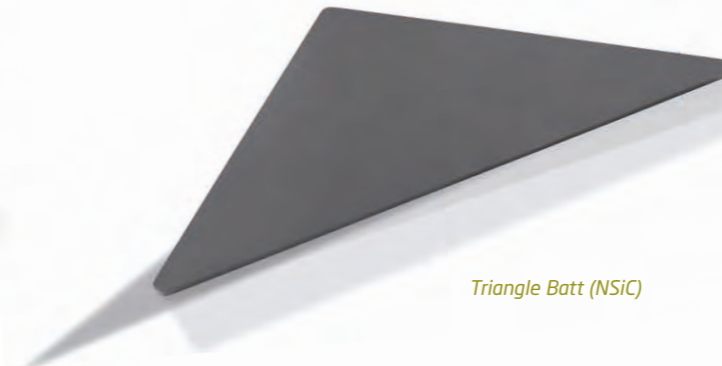

Triangle Batt (NSiC)

Major benefits of Technical SiC-Ceramics made by Schunk Carbon Technology

- ✔ Excellent long term quality-performance
- ✔ Excellent oxidation-/corrosion and thermal shock resistance
- ✔ High degree of reliability and economy in service
- ✔ Low-Mass and therefore reduced gas-consumption
- ✔ Stability of shape up to material specific max. operation temperature
- ✔ Increased firing capacity and degree of flexibility



Powder

Crucibles, bowls and saggars for the firing and heat treatment of pulverized materials (e.g. luminescent powders) fulfill the high demands for thermal shock resistance and low chemical reactivity. In addition to non-oxide ceramics, Schunk Carbon Technology offers a wide range of oxide-ceramic grades.

Crucibles and Bowls (NSiC/RBSiC)

Crucibles and bowls in various shapes and sizes can be designed to customers specifications. Stackable solutions in individual designs – including lids – can be requested.



Crucibles (NSiC/RBSiC)

Major benefits of Technical SiC-Ceramics made by Schunk Carbon Technology

- ↗ Excellent long term quality-performance
- ↗ Low chemical Reactivity, excellent oxidation-/corrosion and thermal shock resistance
- ↗ High degree of reliability and economy in service
- ↗ Low-Mass and therefore reduced gas-consumption
- ↗ Stability of shape up to material specific max. operation temperature
- ↗ Low chemical Reactivity
- ↗ Increased firing capacity and degree of flexibility

Quality Commitment

Quality is in our DNA.

Our commitment and dedication to Quality is reinforced by proven internal processes flanked by intensive quality control and inspection methods within the entire line of manufacturing to ensure a constant high level of quality.

As integrated part of our policy, we are committed to continuously improving our products, processes and services to meet and exceed our customers requirements. Our company is certified according to DIN ISO 9001.

We ensure a high degree of quality in working on customer and application specific measurements prior to shipping as an integrated part of our in-house control. Apart from an optical inspection of the fired product, the material is (depending on the shape) subject to a 100% gauge- and/or 3-point load testing as well as application-specific 3D-Scanning and X-ray measurement.



3D-Scanning of Recuperative Burner

Standard Dimensions

Below listed cross-sections/diameters cover the majority of standard sizes. Intermediate sizes are feasible as well. Larger cross-sections upon request.

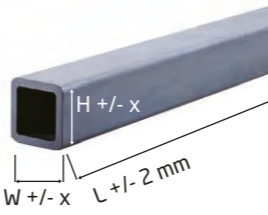
Cross-section		Wall thickness	Tolerances		Moment of resistance	Max. Length	Legend
H (mm)	W (mm)	(mm)	x (mm)	wall (mm)	(mm)	(mm)	
80	80	9	1,4	+1/-0.5	40,789	4,200	
80	60	8,5	1,4	+1/-0.5	32,557	4,200	
60	60	7	1,2	+1/-0.5	21,254	4,200	
60	50	7	1,2	+1/-0.5	18,326	4,200	
60	40	6	1,0	+1/-0.5	15,398	4,200	
50	50	6	1,0	+1/-0.5	13,883	4,200	
50	40	6	1,0	+1/-0.5	11,545	4,200	
50	30	6	1,0	+1/-0.5	9,208	4,200	
40	40	6	1,0	+1/-0.5	8,106	4,200	
40	30	6	1,0	+1/-0.5	6,354	4,200	
40	20	6	1,0	+1/-0.5	4,602	4,200	
35	35	6	1,0	+1/-0.5	5,813	4,200	
30	30	6	1,0	+1/-0.5	3,917	4,200	
30	20	6	1,0	+1/-0.5	2,741	4,200	
25	25	6	1,0	+1/-0.5	2,414	4,200	
20	20	6	1,0	+1/-0.5	1,299	4,200	

The moment of resistance is calculated assuming a constant wall thickness of 6 mm. Special shapes on request. Technical data, right of modification reserved.

* Warpage: $\leq 0,2\%$ (over entire lengths) on all sides. Measurement acc. to DIN 40680.

Eco-Light® Beams

Cross-section	Wall thickness	Warpage*	Max. Length
mm	mm	%	mm
30 x 30	6 +1/-0,5	$\leq 0,10$	3000
25 x 25	6 +1/-0,5	$\leq 0,10$	3000
20 x 20	6 +1/-0,5	$\leq 0,10$	3000

Standard Deviation on two parallel sides according to DIN 40680. Lateral Deviation $\leq 0,2\%$.

* Warpage $\leq 0,1\%$ (over entire lengths) on application side only.



CarSIK Roller

Diameter (mm)		Tolerance X	Max. Lengths
Outer +/- x	Inner	(mm)	(mm)
20	10	+/- 0.3	4200
25	15	+/- 0.4	4200
30	20	+/- 0.5	4200
40	30	+/- 0.6	4200
50	36	+/- 0.7	4200
60	47	+/- 1.0	4200
70	56	+/- 1.2	4200
80	66	+/- 1.4	4200
90	76	+/- 1.6	4200
100	83	+/- 1.8	4200

One respectively both side machining (bores, notch, long hole) is feasible.

* Warpage: TIR ≤ 4 (for $D \leq 50\text{mm}$ and $L < 3000\text{mm}$), larger OD respectively lengths upon request. Special tolerances are feasible by machining upon request (ovality $\leq 0.1\text{mm}$, TIR $\leq 3\text{mm}$, Ra ≤ 1.0).

Roller (RBSiC)

Slabs/Batts

Lengths/width +/-1.5 mm, thickness: +/- 0.7 mm, warpage: $\leq 0.2\%$ (over the diagonal)

Schunk Ingenieurkeramik GmbH

Hanns-Martin-Schleyer-Strasse 5

47877 Willich - Germany

Phone: +49 2154 497 113

Fax: +49 2154 497 111

E-Mail division-carbontechnology@schunk-group.com
schunk-carbontechnology.com

All specifications are subject to technical change. Texts and pictures are subject to copyright laws.
Use of the content is not permitted without the written consent of Schunk Carbon Technology.

35.08e/1000/2018